

ASSEMBLY INSTRUCTION

Name: FS-VarioFloat QuickPack

Model Number: #17.1066

Instruction ID: #00.562_D

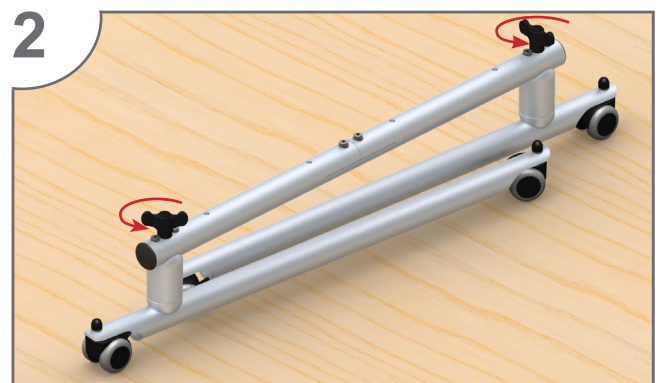
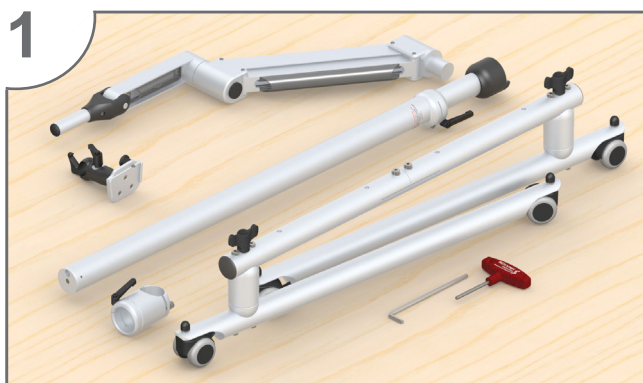

ASSEMBLY INSTRUCTION

Name: FS-VarioFloat QuickPack

Model Number: #17.1066

Instruction ID: #00.562_D

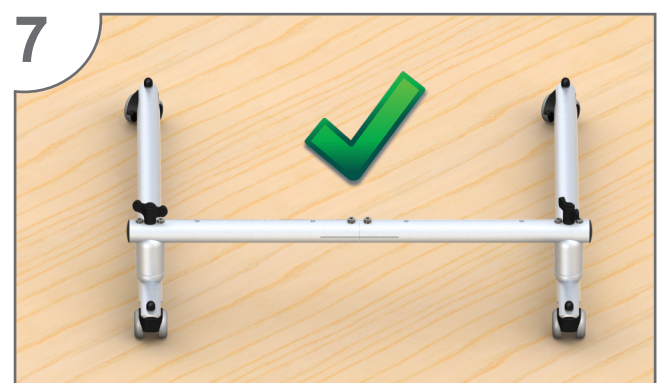
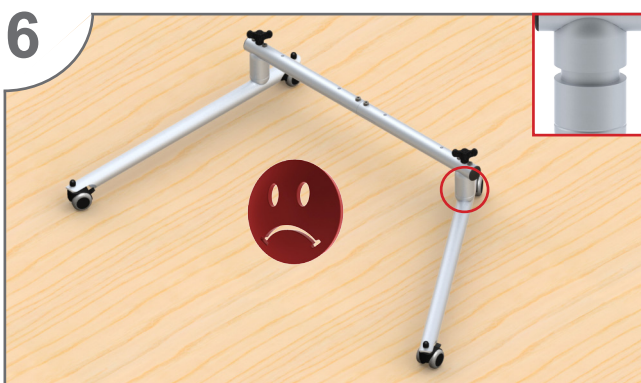
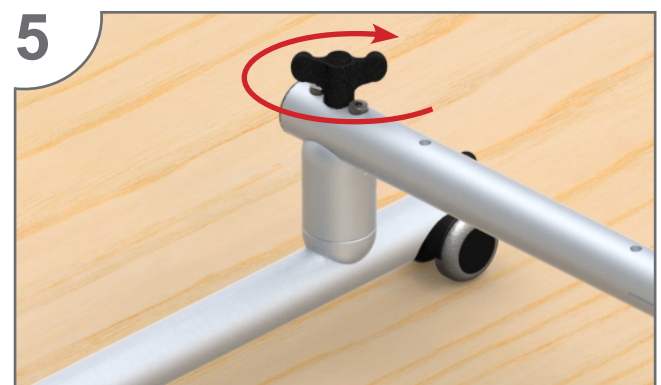
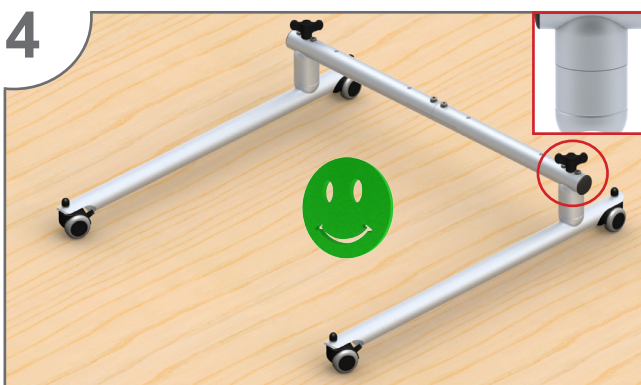
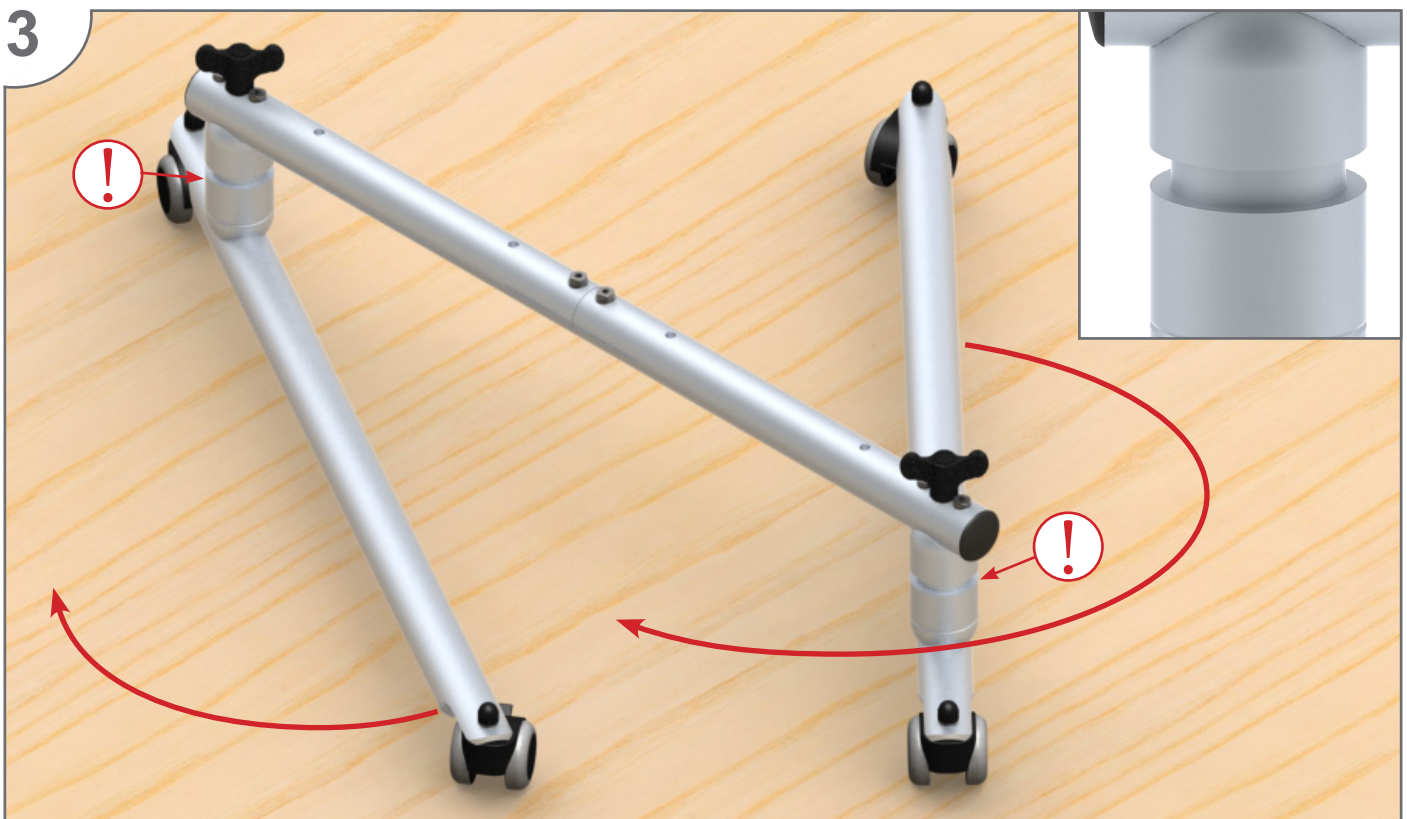

ASSEMBLY INSTRUCTION

Name: FS-VarioFloat QuickPack

Model Number: #17.1066

Instruction ID: #00.562_D

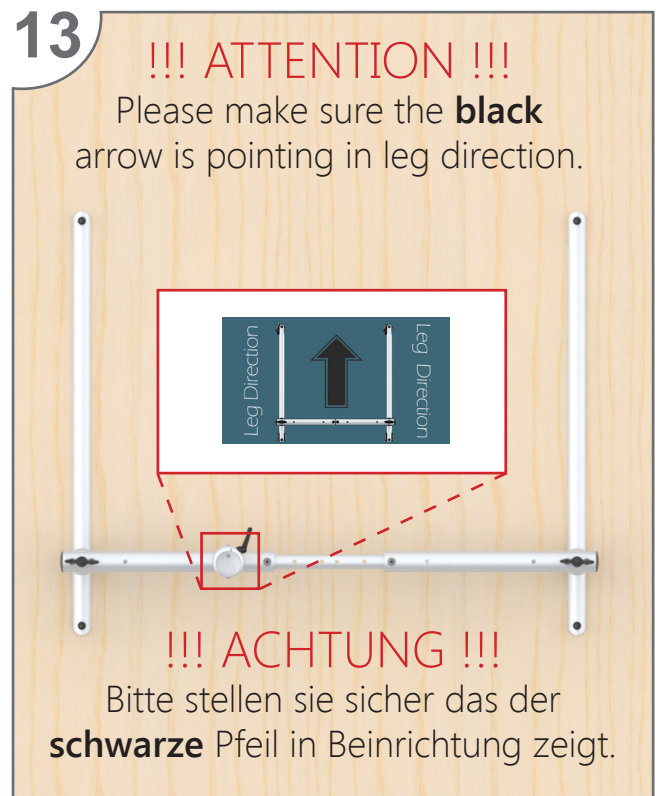
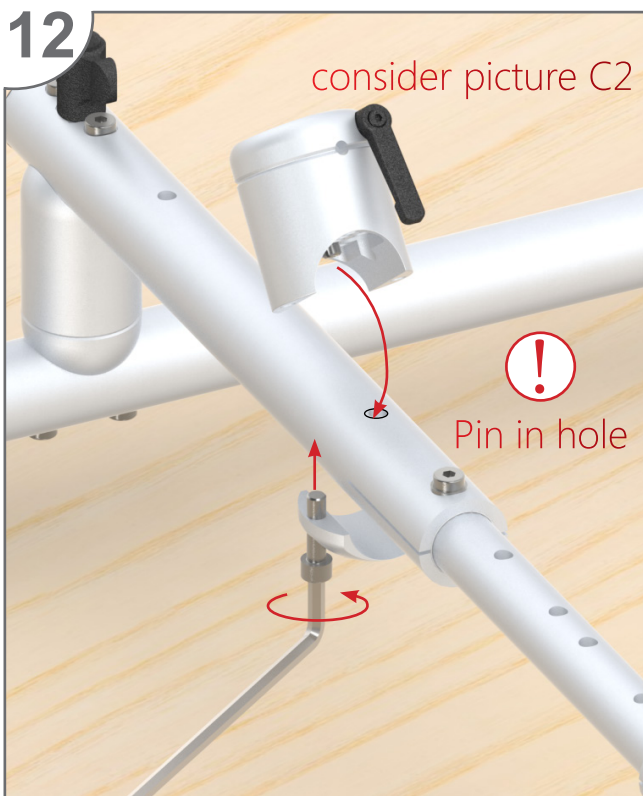
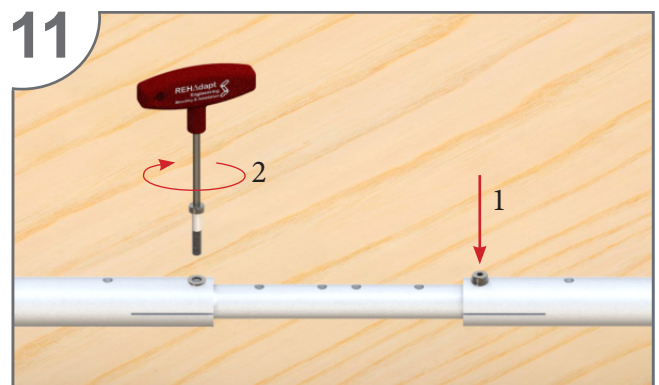
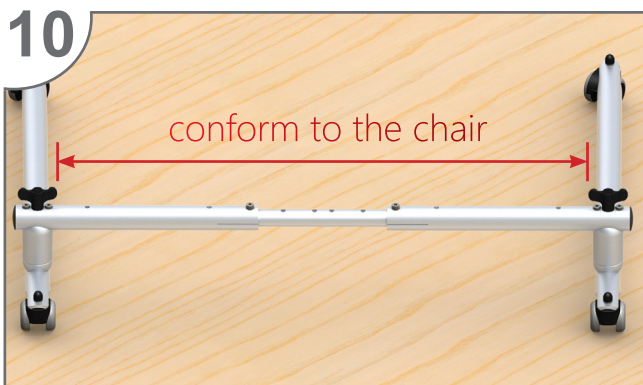
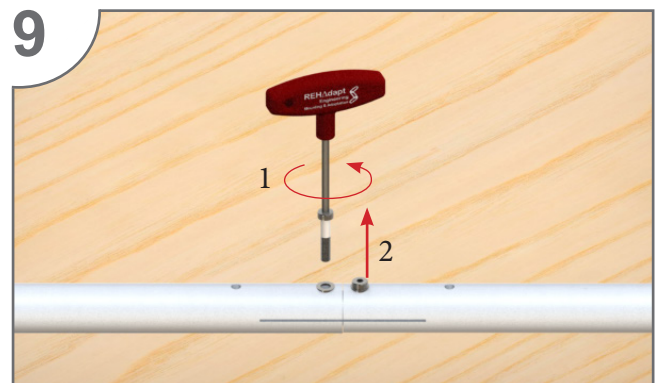
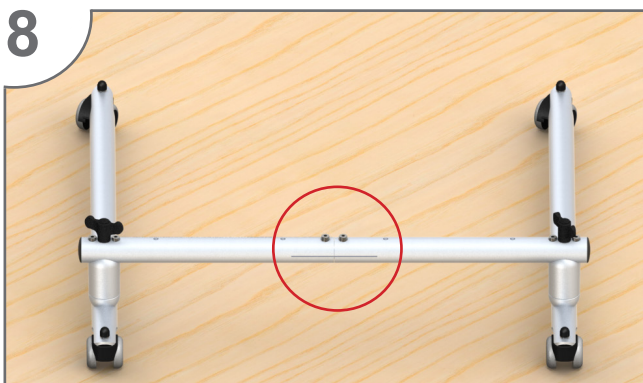

ASSEMBLY INSTRUCTION

Name: FS-VarioFloat QuickPack

Model Number: #17.1066

Instruction ID: #00.562_D

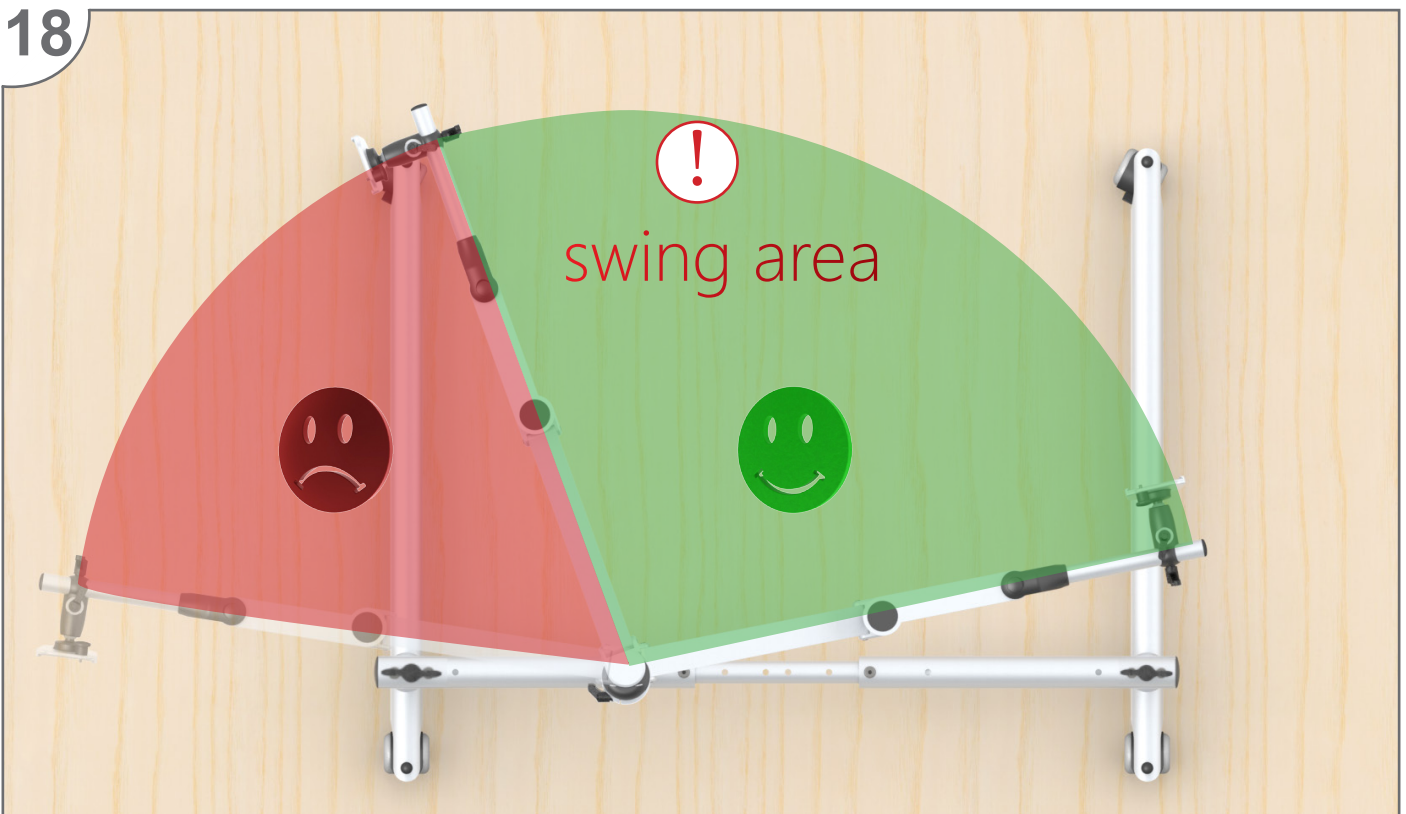
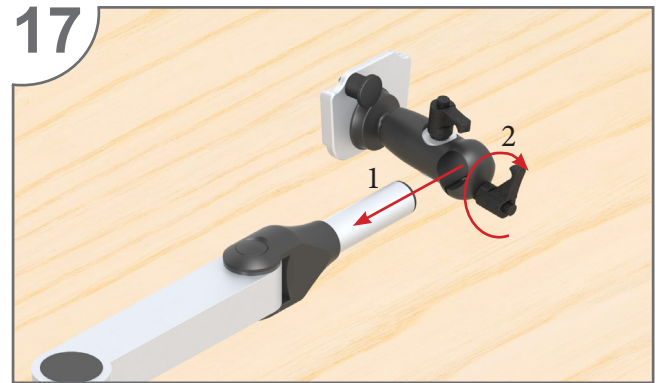
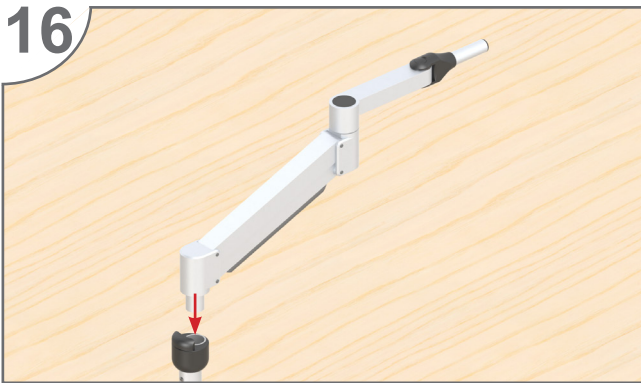
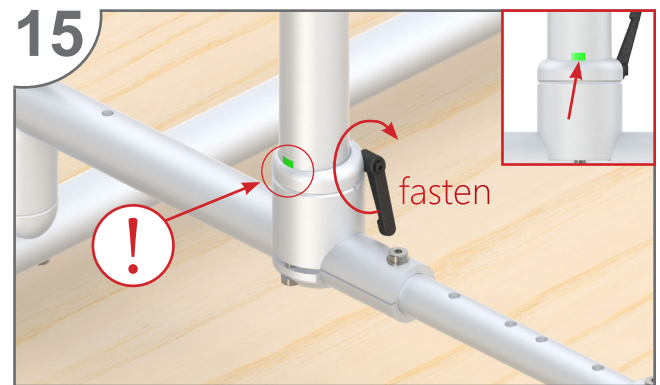
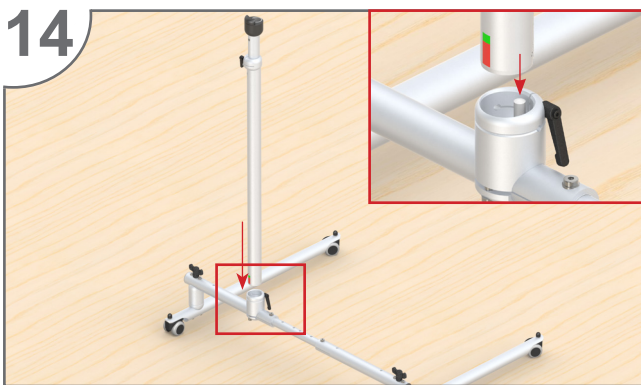

ASSEMBLY INSTRUCTION

Name: FS-VarioFloat QuickPack

Model Number: #17.1066

Instruction ID: #00.562_D

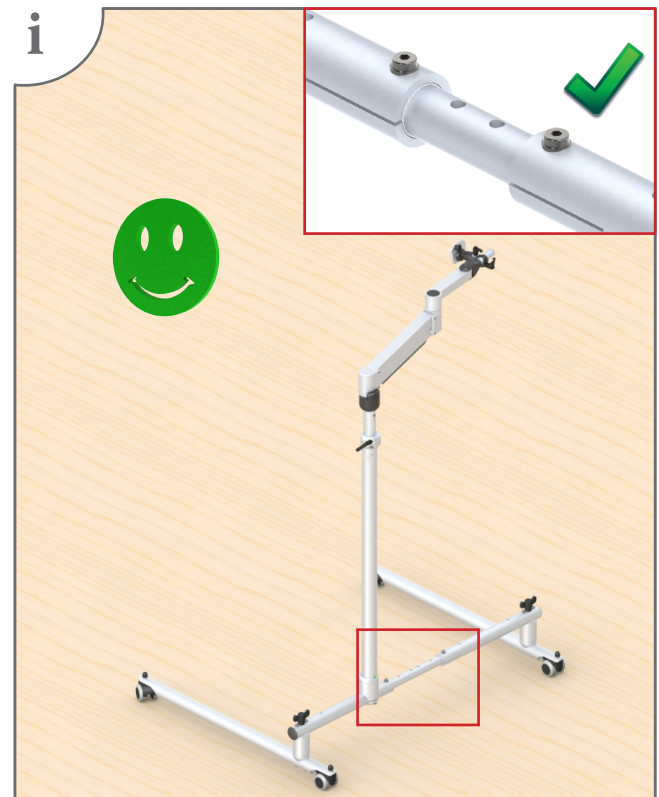
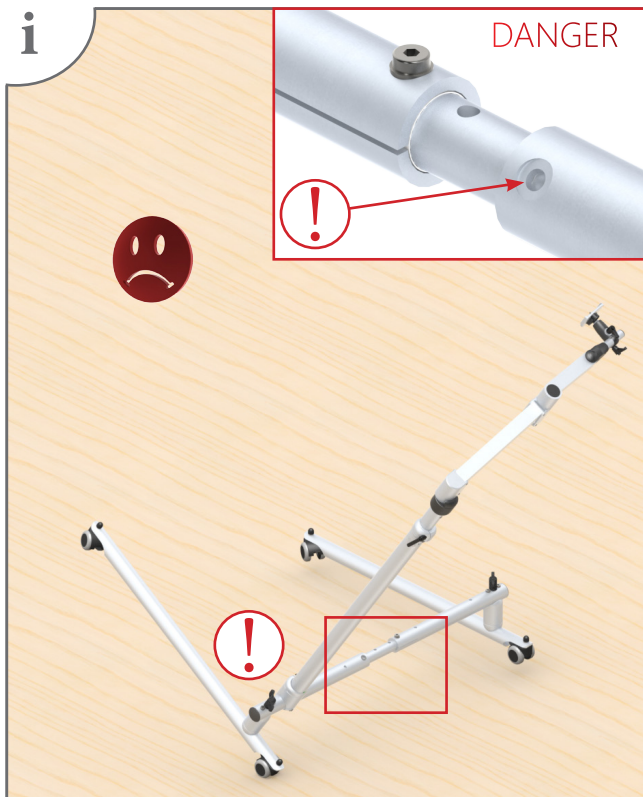

----- Telescope Pole -----

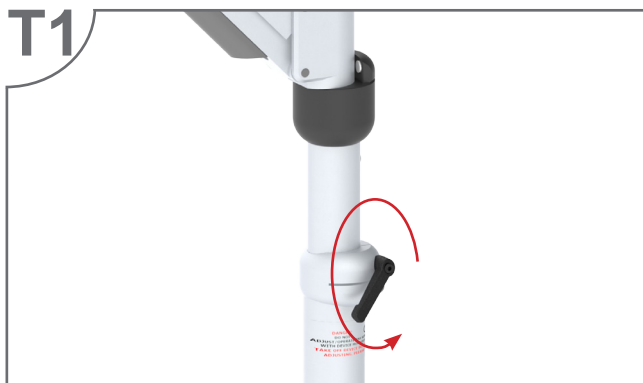

ACHTUNG!

Zur Einstellung des
OneHand Arms
bitte beigefügte
Anleitung beachten!

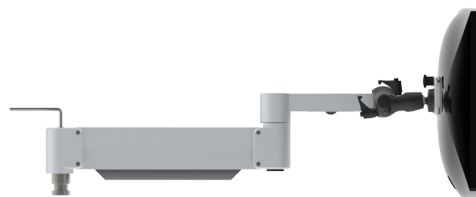

ATTENTION!

For the adjustment of the
OneHand Arm
please see the attached
Instruction sheet!

How do I counterbalance my arm?

Name: FS-Float Arm

Model Number: #17.9610

Instruction ID: #00.563_B

1

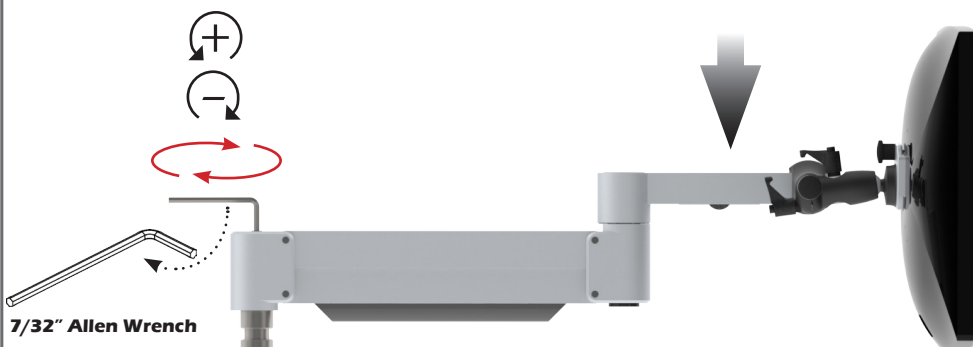

7/32" Allen Wrench

IMPORTANT!

- Monitor must be on arm
- Arm must be in mount

Press the arm down to **approximately parallel** with the desk prior to turning the strength adjustment screw.



If the arm **drifts upward**, turn the adjustment screw clockwise.

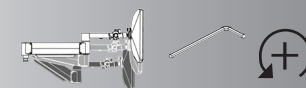

If the arm **drifts downward**, turn the adjustment screw counter-clockwise.

Depending on the weight of your monitor, **you may have to make 15-20 turns**.

2

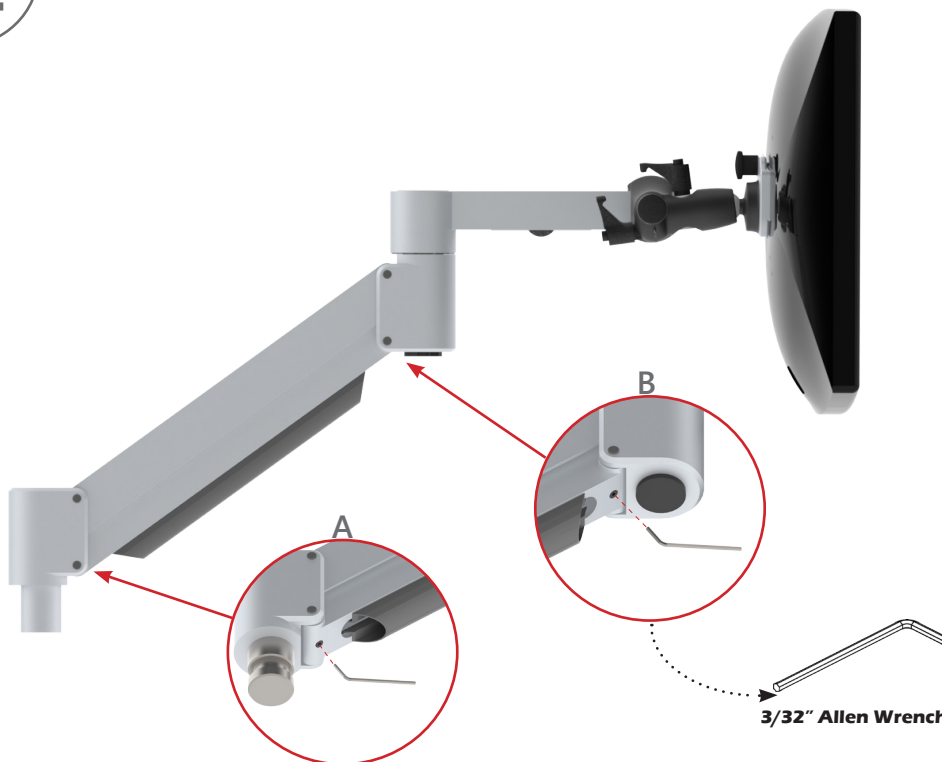

3/32" Allen Wrench

In some instances, further counterbalance adjustments are needed to allow the arm's instant height adjustment function to work properly.

If your arm is not staying in position after performing step 1, follow these steps:



With arm in raised position, tighten set screw **(A)**



With arm in horizontal position, tighten set screw **(B)**

Do not over tighten screws.